

### General Description

890084 is a L1/L2 GPS diplexer in a compact size for use in any GPS application. Designed for rejection of unwanted GPS signals, this SAW diplexer also has excellent power handling capability for low power transmitters.

Housed in a 5.0 x 5.0 mm laminate with over mold package, this device allows for a compact and cost effective diplexer solution for GPS applications.

No matching components are required, making the PCB design and implementation easy.

### Functional Block Diagram

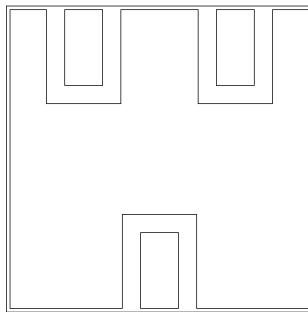

Top View

### Pin Configuration - Single Ended

Pin No.	Label
1	Antenna
2	L1 Band Output
3	L2 Band Output

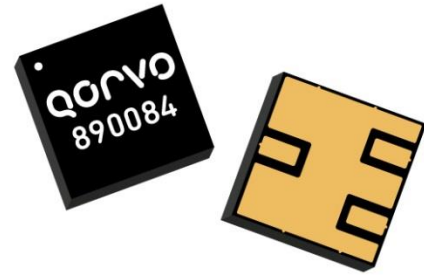

5.0 X 5.0 X 1.1 mm

### Product Features

- Usable bandwidth 20.46 MHz for each Band
- No matching required for operation at 50Ω
- Excellent rejection for GPS operation
- High Isolation
- High Rejection
- Laminate with Over Mold Surface Mount Package (SMP)
- Small Size: 5.0 x 5.0 x 1.1mm
- Hermetic **RoHS** compliant, **Pb-free** 

### Applications

- General purpose GPS
- Communication Systems

### Ordering Information

Part No.	Description
890084	Packaged Part
890084-EVB	Evaluation board

## Absolute Maximum Ratings

Parameter	Rating
Operating Temperature <sup>(1)</sup>	-55 to +85 °C
Storage Temperature <sup>(1)</sup>	-55 to +105 °C
RF Input Power	10 dBm

Notes:

1. Operation of this device outside the parameter ranges given may cause permanent damage.

## Electrical Specifications <sup>(1,2)</sup>

L1 Band GPS					
Parameter <sup>(3)</sup>	Conditions	Min	Typical <sup>(4)</sup>	Max	Units
Center Frequency		-	1575.42	-	MHz
Maximum Insertion Loss	1574.397 – 1576.443 MHz	-	3.7	4.6	dB
	1565.190 – 1585.650 MHz	-	3.9	4.7	
Amplitude Variation	1574.397 – 1576.443 MHz	-	0.1	0.2	dB
	1565.190 – 1585.650 MHz	-	0.3	0.7	
Group Delay Variation	1574.397 – 1576.443 MHz	-	1.8	4.5	ns
	1565.190 – 1585.650 MHz	-	3.3	7.5	
Absolute Attenuation	824.0000 – 960.000 MHz	33	36	-	dB
	1500.000 – 1525.420 MHz	30	36	-	
	1625.420 – 1650.00 MHz	28	34	-	
	1710.000 – 2170.00 MHz	33	37	-	
Return Loss at Port 2	1574.397 – 1576.443 MHz	10	20	-	dB
	1565.190 – 1585.650 MHz	10	19	-	
Nominal Impedance <sup>(5)</sup>	Single Ended	-	50	-	Ohm

Notes:

1. All specifications are based on the Qorvo schematics for the reference designs shown on page 5.
2. In production, devices will be tested at room temperature to a guard banded specification to ensure electrical compliance over temperature.
3. Electrical margin has been built into the design to account for the variations due to temperature drift and manufacture tolerances.
4. Typical values are based on average measurements at room temperature on pcb.
5. This is the optimum impedance in order to achieve the performance shown.

## Electrical Specifications <sup>(1,2)</sup>

L2 Band GPS					
Parameter <sup>(3)</sup>	Conditions	Min	Typical <sup>(4)</sup>	Max	Units
Center Frequency		-	1226.6	-	MHz
Maximum Insertion Loss	1226.577 – 1228.623 MHz	-	2.9	3.5	dB
	1217.370 – 1237.830 MHz		3.2	4.3	
Amplitude Variation	1226.577 – 1228.623 MHz	-	0.1	0.25	dB
	1217.370 – 1237.830 MHz		0.3	1.0	
Group Delay Variation	1226.577 – 1228.623 MHz	-	2.9	7.0	ns
	1217.370 – 1237.830 MHz	-	7	18	
Absolute Attenuation	464.000 – 600.000 MHz	45	48	-	dB
	1150.000 – 1177.600 MHz	24	35	-	dB
	1277.600 – 1300.000 MHz	25	33	-	dB
	1360.000 – 1820.000 MHz	33	35	-	dB
Return Loss at Port 3	1226.577 – 1228.623 MHz	10	20	-	dB
	1217.370 – 1237.830 MHz	9	16		
Nominal Impedance <sup>(5)</sup>	Single Ended	-	50	-	Ohm

L1 Band – L2 Band Specifications					
Parameter <sup>(3)</sup>	Conditions	Min	Typical <sup>(4)</sup>	Max	Units
Nominal Impedance <sup>(5)</sup>	Single Ended	-	50	-	
Antenna Return Loss	1574.397 – 1576.443 MHz	11.0	16	-	dB
	1565.19 – 1585.65 MHz	11.0	16	-	
	1226.577 – 1228.623 MHz	11.0	20	-	
	1217.37 – 1237.83 MHz	10.0	20	-	
Isolation	1574.397 – 1576.443 MHz	37	17		dB
	1565.19 – 1585.65 MHz	37	41		
	1226.577 – 1228.623 MHz	36	39		
	1217.37 – 1237.83 MHz	35	40		

**Notes:**

1. All specifications are based on the Qorvo schematics for the reference designs shown on page 5.
2. In production, devices will be tested at room temperature to a guard banded specification to ensure electrical compliance over temperature.
3. Electrical margin has been built into the design to account for the variations due to temperature drift and manufacture tolerances.
4. Typical values are based on average measurements at room temperature on pcb.
5. This is the optimum impedance in order to achieve the performance shown.

Evaluation Board – 890084-EVB

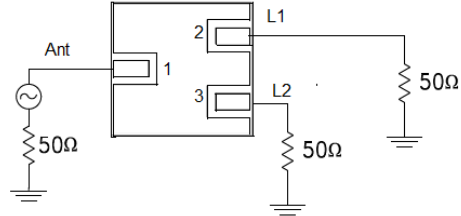
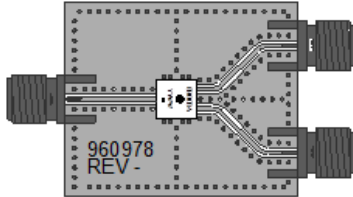

Notes:

1. No Impedance matching required. Value adjustment may be required in end user product circuits depending on component manufacturer and PCB material.  
PCB: .500 x.500 x .062; Construction: ½ oz Cu Top Layer; TLY-5A (.0075) ½ oz Cu Middle Layer, FR4; ½ oz Cu Bottom Layer. (dimensions are in inches)

Bill of Material – 890084-EVB

Reference Des.	Value	Description	Manuf.	Part Number
DUT	-	L1/L2 HA GPS SAW Diplexer	Qorvo	890084
SMA	-	SMA connector	Radiall USA Inc.	9602-1111-018
PCB	-	3-Layer	Qorvo	960978

PCB Mounting Pattern

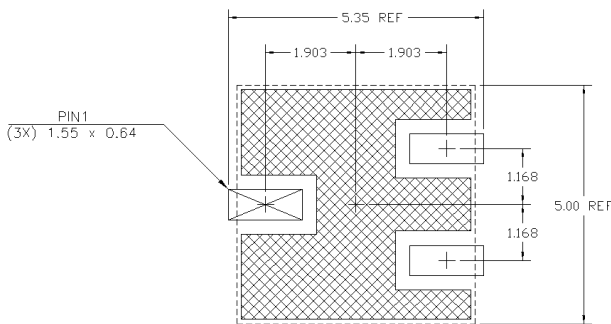

1. All dimensions are in millimeters. Angles are in degrees.
2. This drawing specifies the mounting pattern used on the Qorvo evaluation board for this product. Some modification may be necessary to suit end user assembly materials and processes.

L1 Typical Performance (at room temperature)

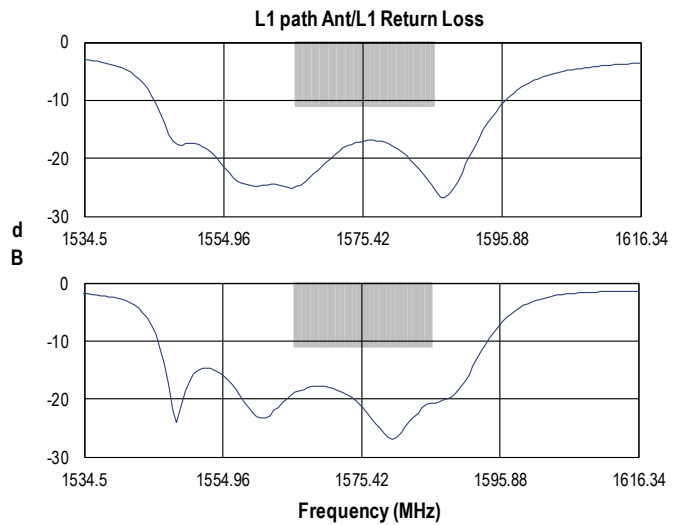
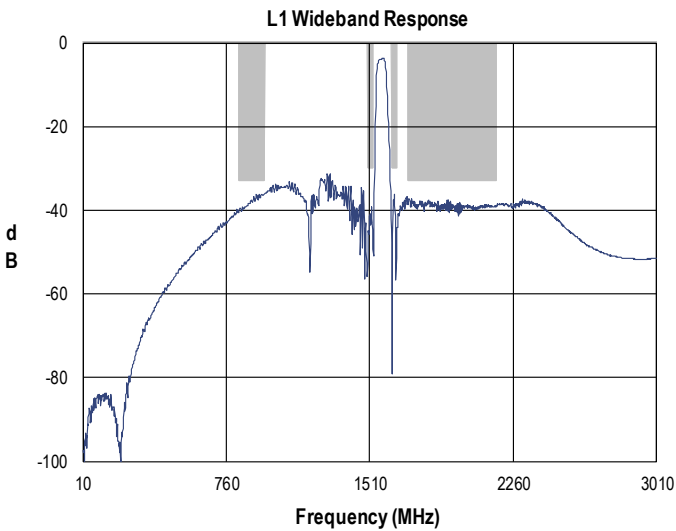
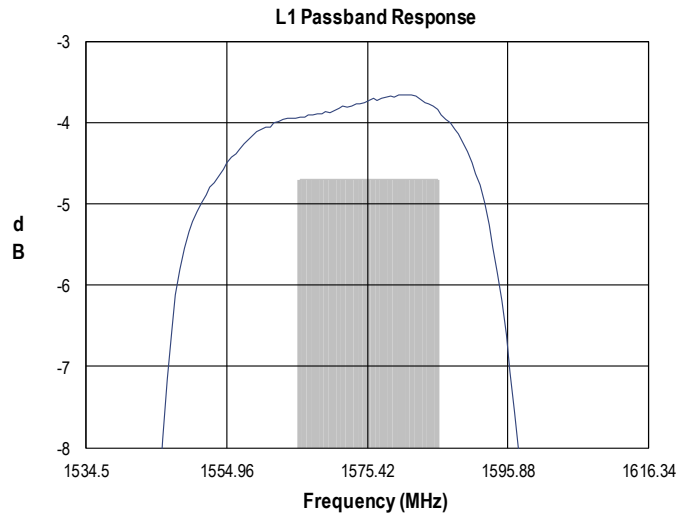
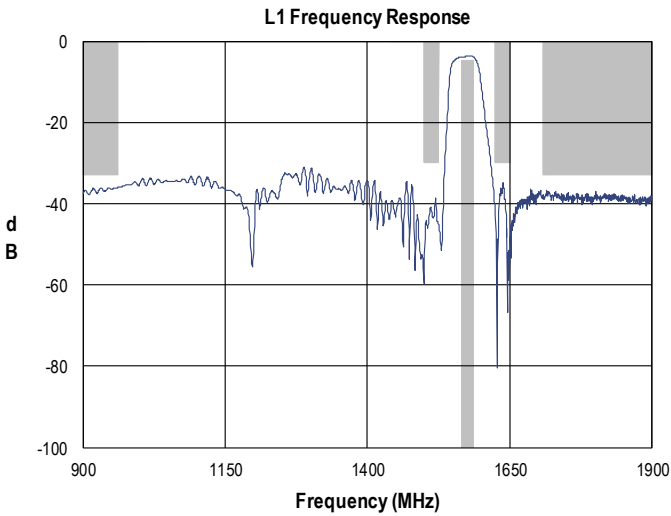

L1 Path - Ant Port Impedance

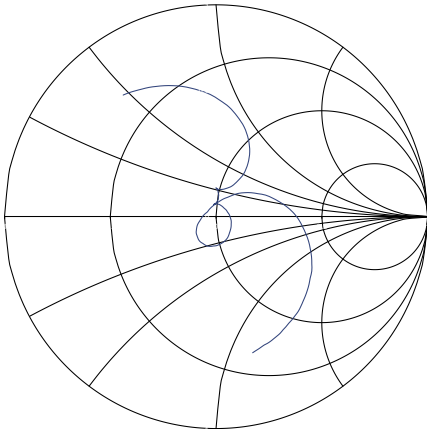

L1 Port Impedance

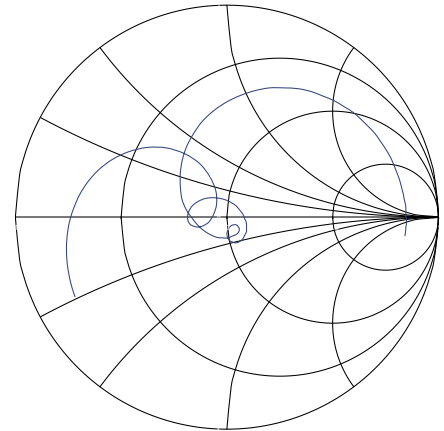

L2 Typical Performance (at room temperature)

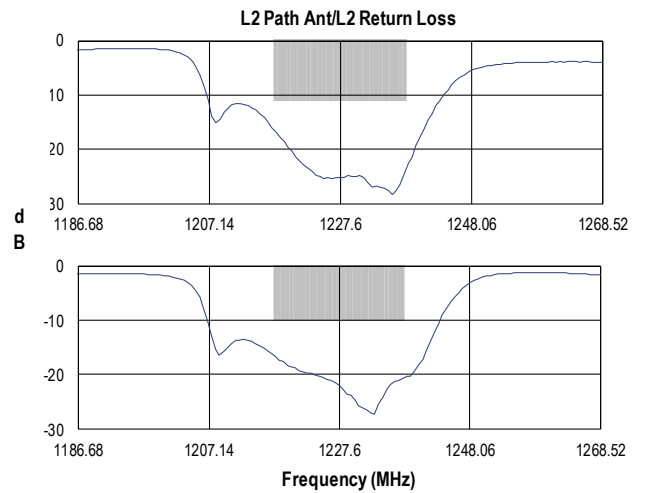
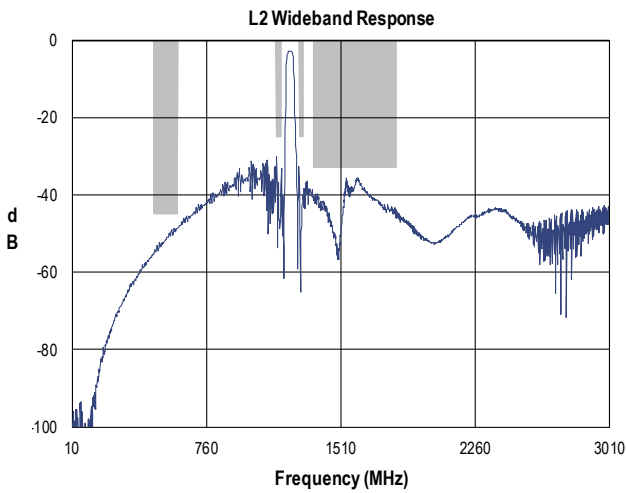
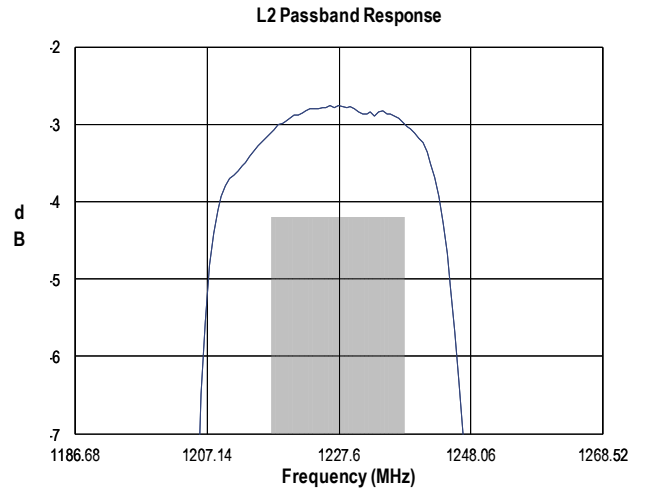
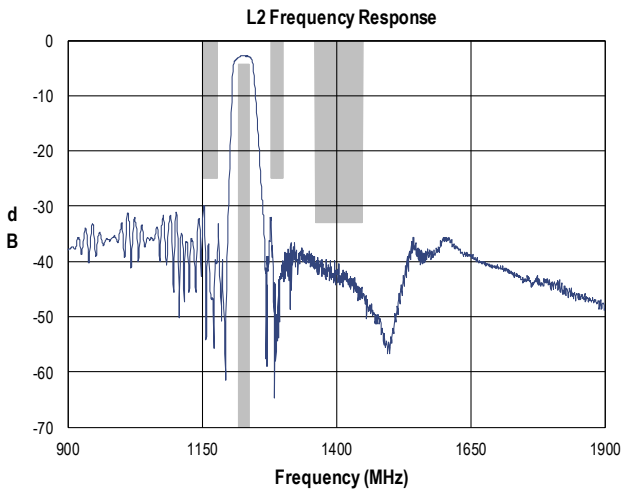

L2 Path - Ant Port Impedance

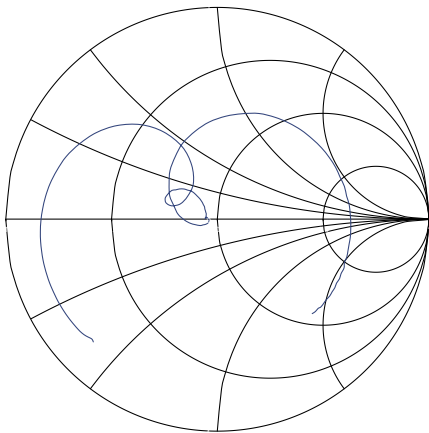

L2 Port Impedance

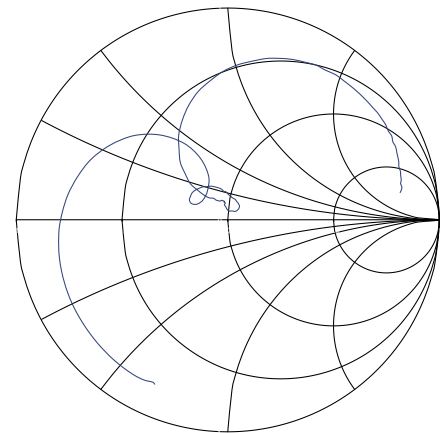

### Isolation Performance

---

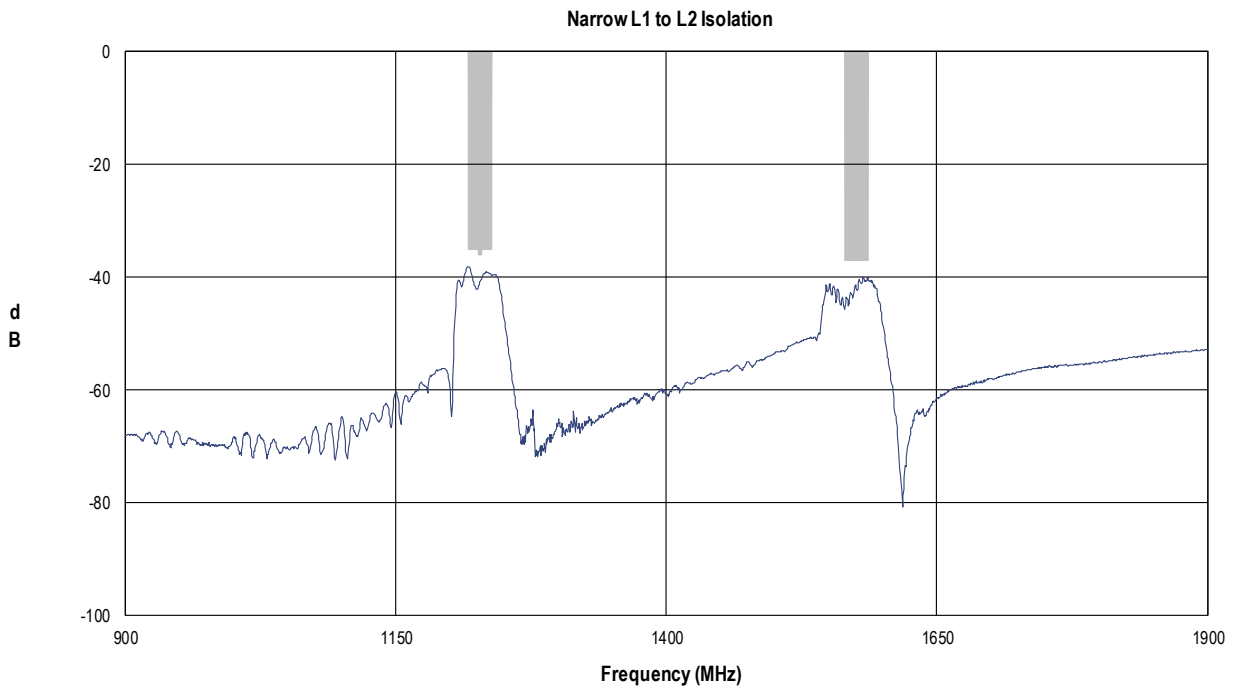

Package Information, Marking and Dimensions

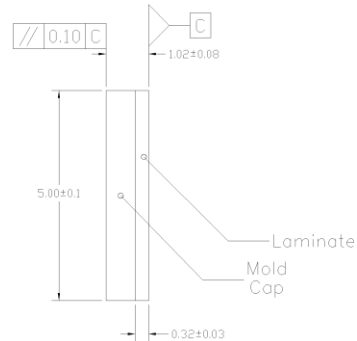
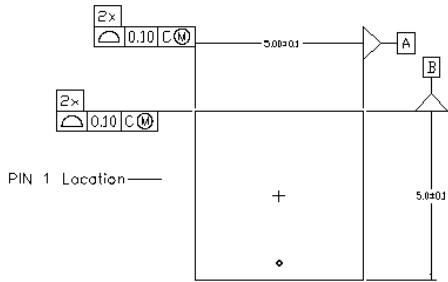

Package Style: 5X5 Module  
 Dimensions: 5 X 5 X 1.1 mm

All dimensions are in millimeters. Angles are in degrees

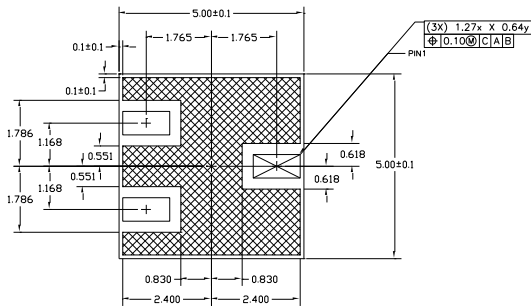

Tape and Reel Information

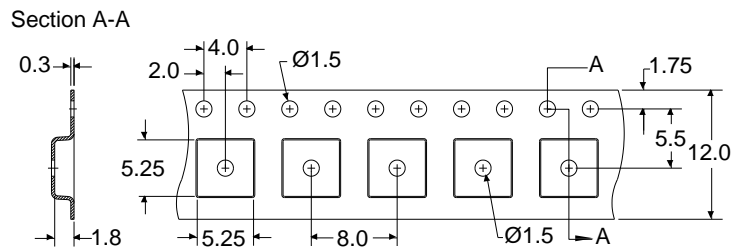
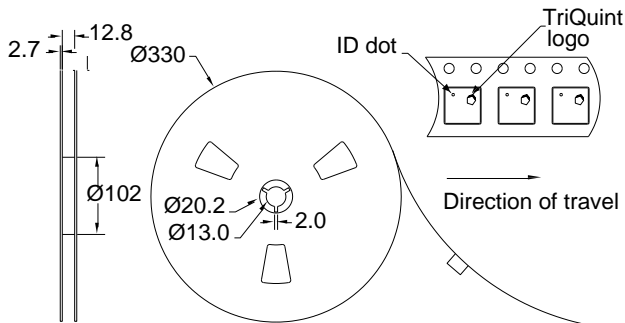

## Handling Precautions

Parameter	Rating	Standard
ESD – Human Body Model (HBM)	Class 3B	ESDA / JEDEC JS-001
ESD – Charged Device Model (CDM)	Class C3	ESDA / JEDEC JS-002
MSL – Moisture Sensitivity Level	Level 3	JEDEC Standard IPC/JEDEC J-STD-020



Caution!  
ESD-Sensitive Device

## Solderability

Compatible with both lead-free (260°C max. reflow temp.) and tin/lead (245°C max. reflow temp.) soldering processes.

Solder profiles available upon request.

Refer to [Soldering Profile](#) for recommended guidelines

## RoHS Compliance

This part is compliant with EU 2002/95/EC RoHS directive (Restrictions on the Use of Certain Hazardous Substances in Electrical and Electronic Equipment). This product also has the following attributes:

- Lead Free
- Halogen Free (Chlorine, Bromine)
- Antimony Free
- TBBP-A (C<sub>15</sub>H<sub>12</sub>Br<sub>4</sub>O<sub>2</sub>) Free
- PFOS Free
- SVHC Free
- Qorvo Green



## Contact Information

For the latest specifications, additional product information, worldwide sales and distribution locations:

Web: [www.qorvo.com](http://www.qorvo.com)

Tel: 1-844-890-8163

Email: [customer.support@qorvo.com](mailto:customer.support@qorvo.com)

For technical questions and application information: Email: [fapplication.engineering@qorvo.com](mailto:fapplication.engineering@qorvo.com)

## Important Notice

The information contained herein is believed to be reliable; however, Qorvo makes no warranties regarding the information contained herein and assumes no responsibility or liability whatsoever for the use of the information contained herein. All information contained herein is subject to change without notice. Customers should obtain and verify the latest relevant information before placing orders for Qorvo products. The information contained herein or any use of such information does not grant, explicitly or implicitly, to any party any patent rights, licenses, or any other intellectual property rights, whether with regard to such information itself or anything described by such information. **THIS INFORMATION DOES NOT CONSTITUTE A WARRANTY WITH RESPECT TO THE PRODUCTS DESCRIBED HEREIN, AND QORVO HEREBY DISCLAIMS ANY AND ALL WARRANTIES WITH RESPECT TO SUCH PRODUCTS WHETHER EXPRESS OR IMPLIED BY LAW, COURSE OF DEALING, COURSE OF PERFORMANCE, USAGE OF TRADE OR OTHERWISE, INCLUDING THE IMPLIED WARRANTIES OF MERCHANTABILITY AND FITNESS FOR A PARTICULAR PURPOSE.**

Without limiting the generality of the foregoing, Qorvo products are not warranted or authorized for use as critical components in medical, life-saving, or life-sustaining applications, or other applications where a failure would reasonably be expected to cause severe personal injury or death.

Copyright 2016 © Qorvo, Inc. | Qorvo is a registered trademark of Qorvo, Inc.