



3-pin SOT-89 Package

### General Description

The TQP3M9008 is a cascadable, high linearity gain block amplifier in a low-cost surface-mount package. At 1.9GHz, the amplifier typically provides 20.6dB gain, +36dBm OIP3, and 1.3dB Noise Figure while only drawing 85 mA current. The device is housed in a lead-free/green/RoHS-compliant industry-standard SOT-89 package.

The TQP3M9008 has the benefit of having high gain across a broad range of frequencies while also providing very low noise. This allows the device to be used in both receiver and transmitter chains for high performance systems. The amplifier is internally matched using a high performance E-pHEMT process and only requires an external RF choke and blocking/bypass capacitors for operation from a single +5V supply. The internal active bias circuit also enables stable operation over bias and temperature variations.

The TQP3M9008 covers the 0.05 – 4 GHz frequency band and is targeted for wireless infrastructure or other applications requiring high linearity and/or low noise figure.

### Functional Block Diagram

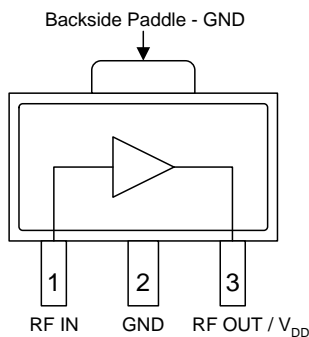

### Product Features

- 50 – 4000 MHz
- 20.6 dB Gain at 1.9 GHz
- +36 dBm Output IP3
- 1.3 dB Noise Figure at 1.9 GHz
- 50 Ohm Cascadable Gain Block
- Unconditionally stable
- High input power capability
- +5 V Single Supply, 85 mA Current
- SOT-89 Package

### Applications

- Repeaters
- Mobile Infrastructure
- LTE / WCDMA / EDGE / CDMA
- General Purpose Wireless

### Ordering Information

Part No.	Description
TQP3M9008	High Linearity LNA Gain Block
TQP3M9008-PCB_IF	0.05–0.5 GHz Evaluation Board
TQP3M9008-PCB_RF	0.5–4.0 GHz Evaluation Board

Standard T/R size = 1000 pieces on a 7" reel

## Absolute Maximum Ratings

Parameter	Rating
Storage Temperature	-65 to 150 °C
RF Input Power, CW, 50Ω, T=25°C	+23 dBm
Device Voltage (V <sub>DD</sub> )	+7 V
Reverse Device Voltage	-0.3 V

Operation of this device outside the parameter ranges given above may cause permanent damage.

## Recommended Operating Conditions

Parameter	Min	Typ	Max	Units
Device Voltage (V <sub>DD</sub> )	+3.0	+5.0	+5.25	V
T <sub>CASE</sub>	-40		+105	°C
T <sub>j</sub> for >10 <sup>6</sup> hours MTTF			+190	°C

Electrical specifications are measured at specified test conditions. Specifications are not guaranteed over all recommended operating conditions.

## Electrical Specifications

Test conditions unless otherwise noted: V<sub>DD</sub>= +5 V, Temp. = +25 °C, 50 Ω system

Parameter	Conditions	Min	Typ	Max	Units
Operational Frequency Range		50		4000	MHz
Test Frequency			1900		MHz
Gain		19	20.6	22	dB
Input Return Loss			16		dB
Output Return Loss			17		dB
Output P1dB			+20		dBm
Output IP3	P <sub>out</sub> = +3 dBm/tone, Δf = 1 MHz	+32.5	+36		dBm
Noise Figure			1.3		dB
Current, I <sub>DD</sub>			85	100	mA
Thermal Resistance, θ <sub>jc</sub>	Junction to case			38.7	°C/W

## S-Parameters

Test Conditions:  $V_{DD}=+5\text{ V}$ ,  $I_{DD}=85\text{ mA}$ , Temp. =  $+25\text{ }^{\circ}\text{C}$ ,  $50\text{ }\Omega$  system, calibrated to device leads

Freq (MHz)	S11 (dB)	S11 (ang)	S21 (dB)	S21 (ang)	S12 (dB)	S12 (ang)	S22 (dB)	S22 (ang)
50	-12.5	-170.0	23.6	172.9	-26.7	0.6	-9.8	177.2
100	-11.9	-175.1	23.5	167.7	-26.7	-1.9	-9.9	171.9
200	-11.4	178.0	23.1	159.5	-26.6	-5.5	-10.0	162.2
400	-11.4	167.0	22.7	144.1	-26.7	-12.9	-10.5	145.5
600	-11.6	154.1	22.3	129.4	-26.7	-19.6	-10.7	129.3
800	-11.8	147.2	22.0	114.6	-26.7	-26.1	-11.3	111.8
1000	-12.3	139.1	21.7	99.5	-26.8	-33.4	-12.4	94.3
1200	-12.7	132.1	21.4	85.6	-26.9	-39.9	-13.1	77.8
1400	-13.3	126.3	21.0	71.0	-27.1	-47.7	-14.3	58.7
1600	-13.6	116.9	20.8	56.2	-27.4	-56.5	-15.4	36.8
1800	-13.9	110.2	20.5	41.8	-27.6	-63.3	-16.3	15.3
2000	-14.3	103.5	20.3	27.9	-28.1	-71.6	-17.5	-11.2
2200	-15.1	94.6	19.9	13.8	-28.5	-80.2	-18.0	-39.1
2400	-15.8	85.2	19.7	-1.1	-28.7	-88.9	-17.4	-65.9
2600	-16.8	72.7	19.5	-16.0	-29.4	-96.8	-16.6	-94.2
2800	-18.0	55.2	19.2	-31.3	-29.9	-105.7	-14.9	-115.0
3000	-19.8	25.5	19.0	-46.9	-30.6	-117.1	-14.1	-131.7
3200	-19.9	-16.8	18.6	-63.5	-31.0	-128.0	-13.1	-148.3
3400	-17.8	-59.0	18.3	-80.5	-31.8	-139.4	-12.4	-160.2
3600	-14.3	-90.8	17.7	-98.5	-32.8	-154.4	-11.9	-173.9
3800	-11.3	-114.3	17.0	-117.1	-34.0	-168.1	-11.2	174.5
4000	-8.7	-132.7	16.1	-135.8	-34.8	173.1	-10.7	167.6

## TQP3M9008-PCB\_IF / RF Evaluation Board

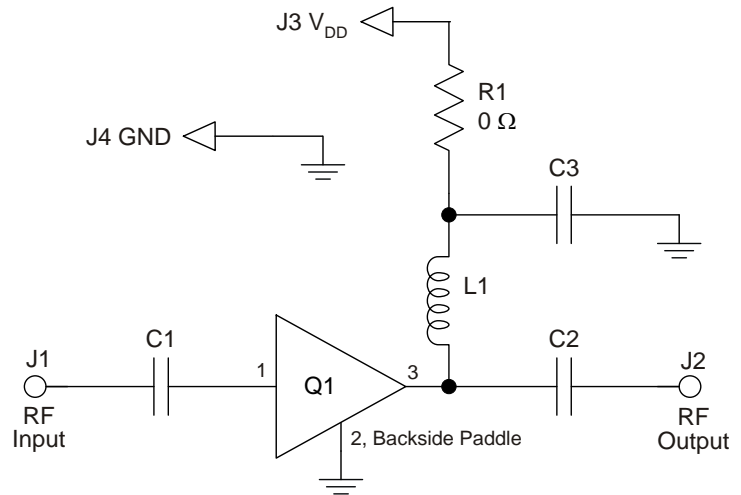
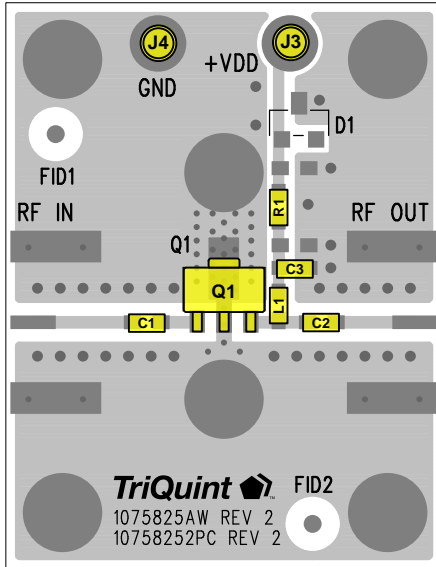

**Notes:**

1. See Evaluation Board PCB section for material and stack-up.
2. Components shown on the silkscreen but not on the schematic are not used.
3. R1 (0  $\Omega$  jumper) may be replaced with copper trace in the target application layout.
4. The recommended component values are dependent upon the frequency of operation.
5. All components are of 0603 size unless stated on the schematic.

## Bill of Material – TQP3M9008-PCB\_IF / RF

Reference Designation	TQP3M9008-PCB_IF (500~500 MHz)	TQP3M9008-PCB_RF (500~4000MHz)
Q1	TQP3M9008	TQP3M9008
C1, C2	1000 pF	100 pF
C3	0.01 uF	0.01 uF
L1	330 nH	68 nH
D1	Do Not Place	
R1	0 $\Omega$	

Performance can be optimized at frequency of interest by using recommended component values shown in the table below.

Reference Designation	500 (MHz)	2000 (MHz)	2500 (MHz)	3500 (MHz)
C1, C2	100 pF	22 pF	22 pF	22 pF
L1	82 nH	22 nH	18 nH	15 nH

## Typical Performance – TQP3M9008-PCB\_RF

Test conditions unless otherwise noted:  $V_{DD}=+5\text{ V}$ ,  $I_{DD}=85\text{ mA}$ ,  $\text{Temp}=+25\text{ }^\circ\text{C}$ ,  $50\ \Omega$  system

Parameter	Typical Value						Units
Frequency	500	900	1900	2700	3500	4000	MHz
Gain	22.8	22.3	20.6	19.0	17.6	16.0	dB
Input Return Loss	10	12	16	18	10	7.3	dB
Output Return Loss	9.5	12	17	13	12.4	14	dB
Output P1dB	+20.9	+19.7	+19.9	+19.4	+19.7	+18.5	dBm
OIP3	+37.5	+37.6	+36	+35.3	+34.7	+33.7	dBm
Noise figure	1.1	1.1	1.3	1.6	2	2.5	dB

Notes:

1. OIP3 measured with two tones at an output power of +3 dBm / tone separated by 1 MHz.
2. Noise figure values in the table above includes board losses. Approx. =0.1dB at 2 GHz.

## Performance Plots – TQP3M9008-PCB\_RF

Test conditions unless otherwise noted:  $V_{DD}=+5\text{ V}$ ,  $I_{DD}=85\text{ mA}$ ,  $\text{Temp}.=+25\text{ }^\circ\text{C}$ ,  $50\ \Omega$  system

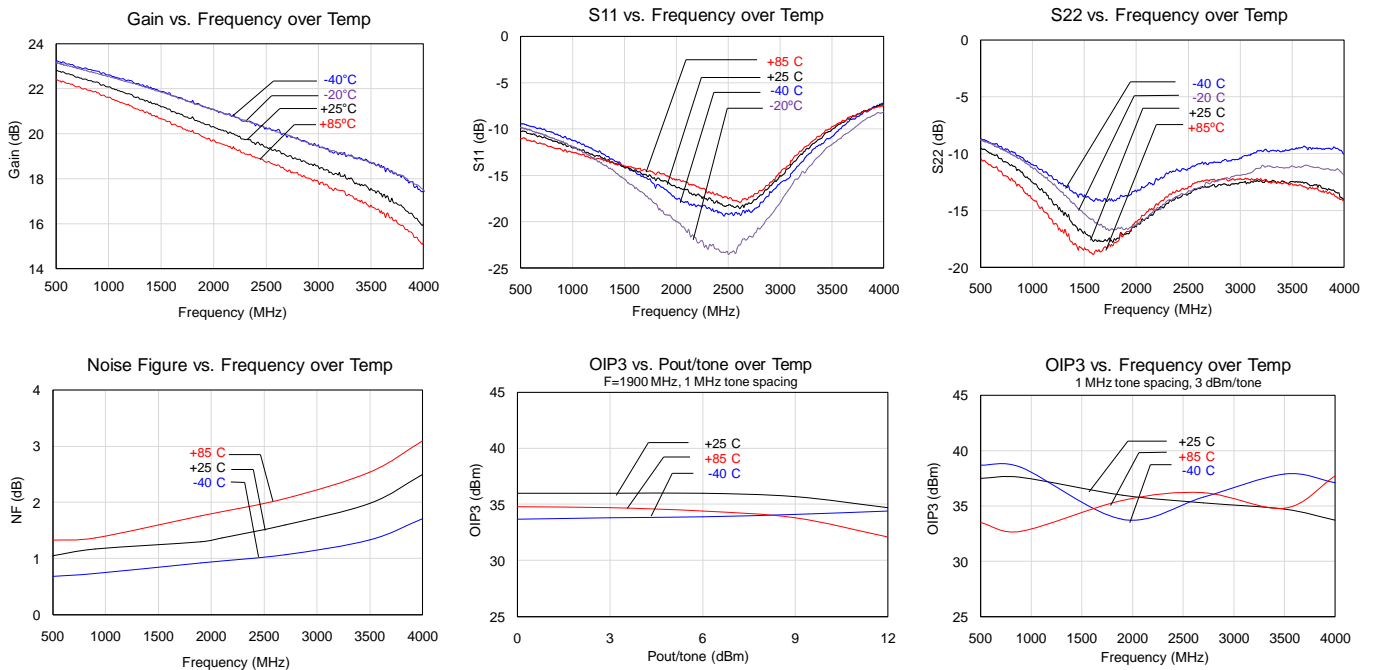

### Performance Plots – TQP3M9008-PCB\_RF

Test conditions unless otherwise noted:  $V_{DD} = +5\text{ V}$ ,  $I_{DD} = 85\text{ mA}$ ,  $\text{Temp.} = +25\text{ }^{\circ}\text{C}$ ,  $50\text{ }\Omega$  system

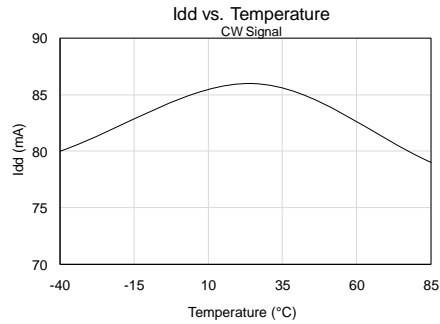
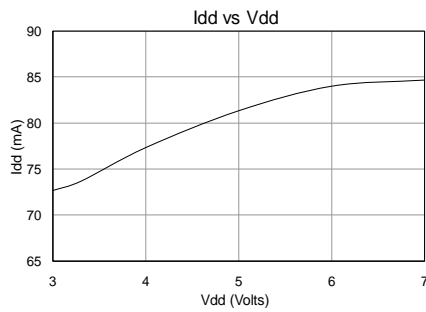
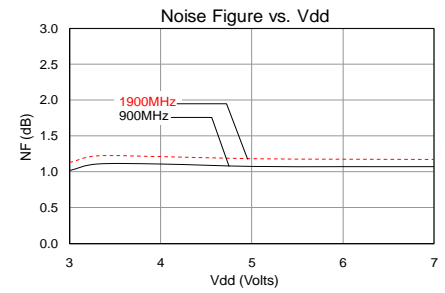
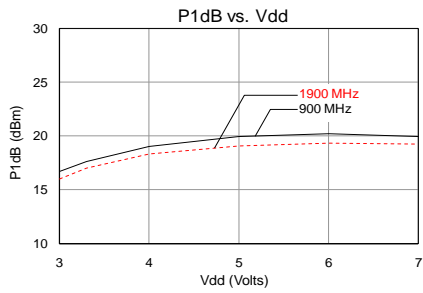
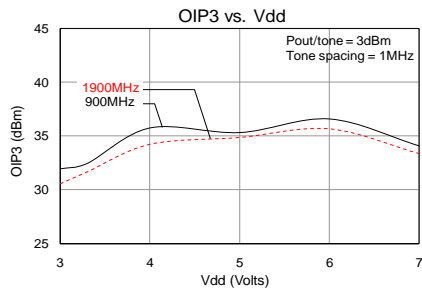
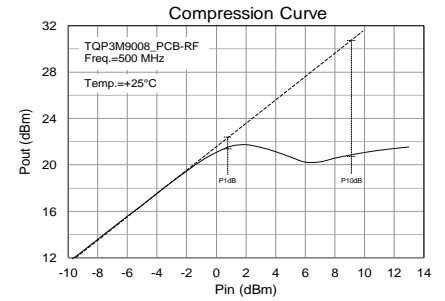
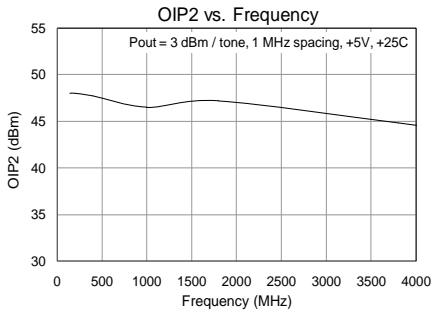
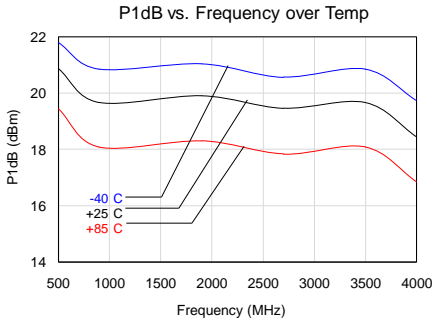

## Typical Performance – TQP3M9008-PCB\_IF

Test conditions unless otherwise noted:  $V_{DD} = +5\text{ V}$ ,  $I_{DD} = 85\text{ mA}$ , Temp. =  $+25\text{ }^{\circ}\text{C}$ ,  $50\ \Omega$  system

Parameter	Typical Value				Units
Frequency	70	100	200	500	MHz
Gain	23.2	23.2	22.9	22.3	dB
Input Return Loss	10	11	11	11	dB
Output Return Loss	9	9	10	10	dB
Output P1dB	+19.8	+20.2	+19.9	+19.9	dBm
OIP3	+37	+37	+37	+37	dBm
Noise figure	1.2	1.1	0.8	1.1	dB

Notes:

- OIP3 measured with two tones at an output power of +3 dBm / tone separated by 1 MHz.
- Noise figure values in the table above includes board losses. Approx. =0.1dB at 2 GHz.

## Performance Plots – TQP3M9008-PCB\_IF

Test conditions unless otherwise noted:  $V_{DD} = +5\text{ V}$ ,  $I_{DD} = 85\text{ mA}$ , Temp =  $+25\text{ }^{\circ}\text{C}$ ,  $50\ \Omega$  system.

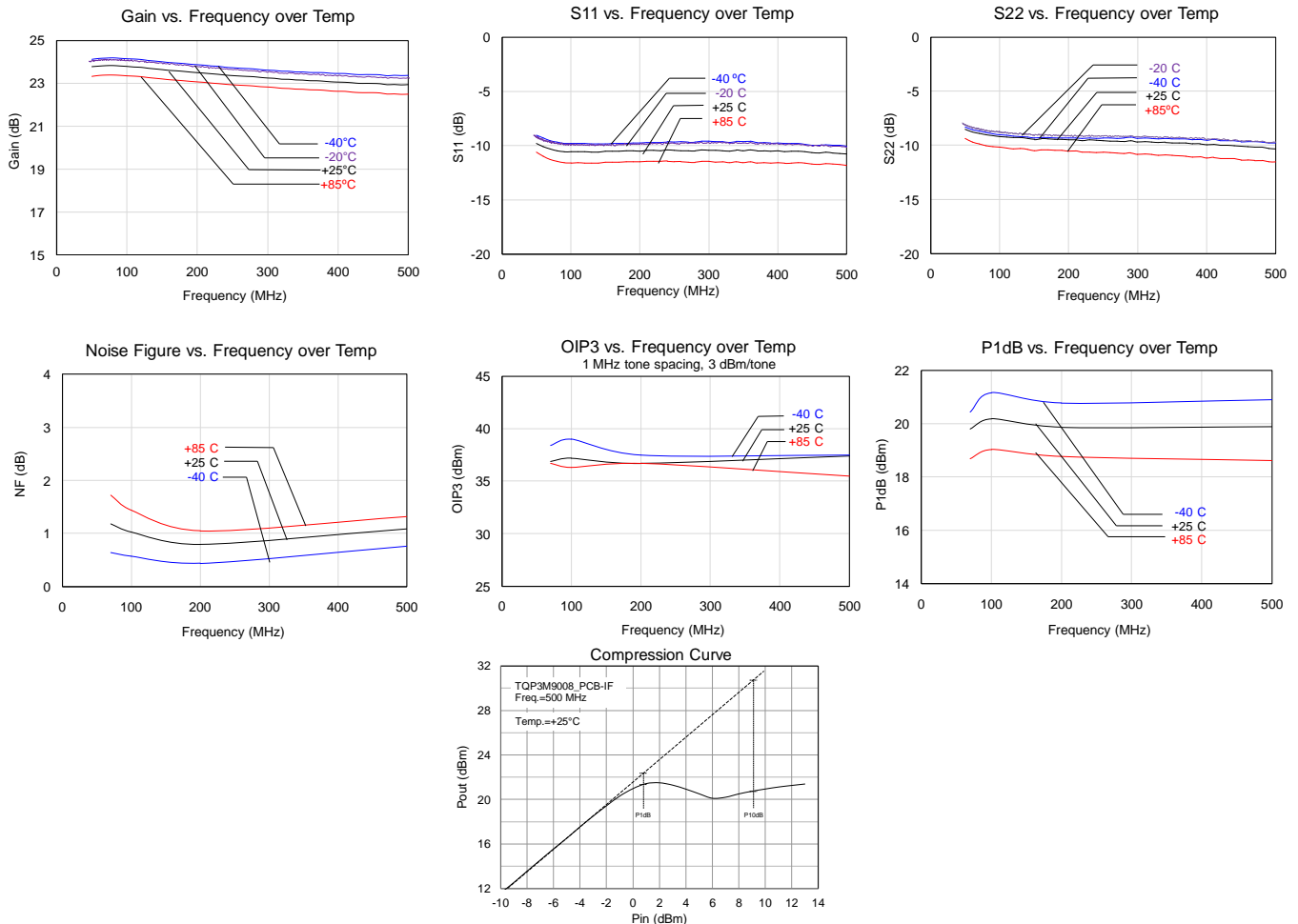

## Pin Configuration and Description

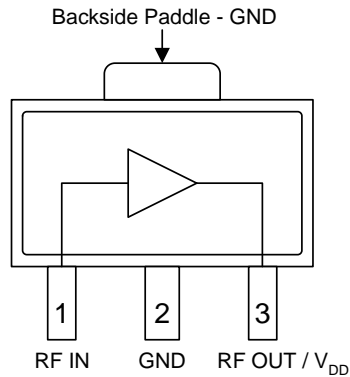

Pin No.	Label	Description
1	RF IN	RF input; matched to 50 ohms. External DC Block is required.
2, Backside Paddle	GND	RF/DC ground. Use recommended via hole pattern to minimize inductance and thermal resistance. See PCB Mounting Pattern for suggested footprint.
3	RF OUT / V <sub>DD</sub>	RF output, matched to 50 ohms. External DC Block and bias voltage required.

## Evaluation Board PCB

Qorvo PCB 1075825 Material and Stack-up

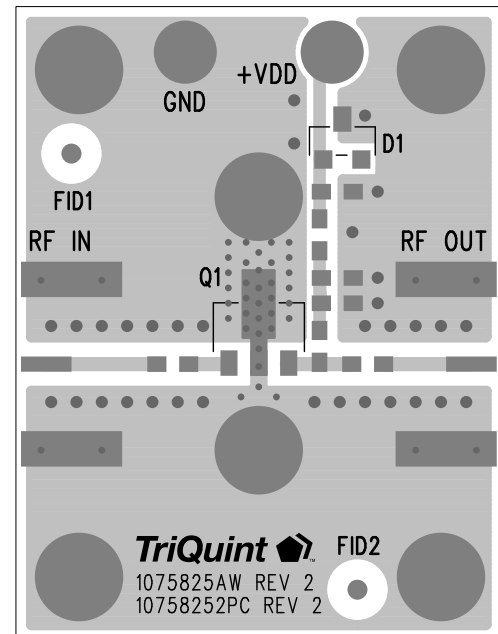
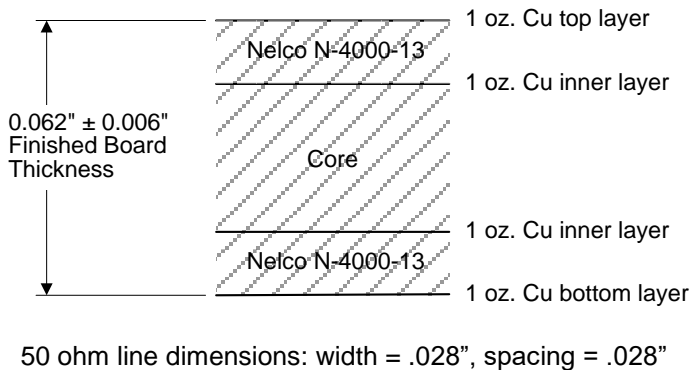

## Package Marking and Dimensions

### Package Marking

Product Identifier: 3M9008  
Lot Code: XXXX

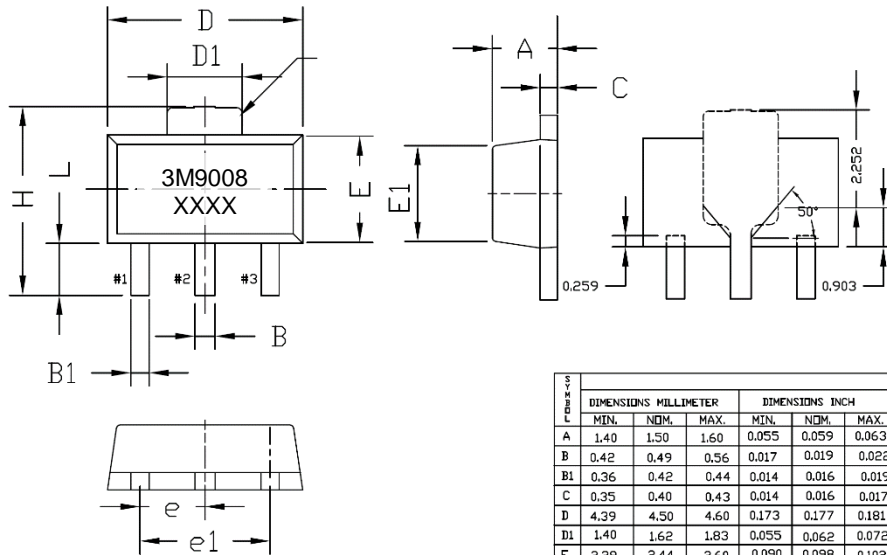

SYMBOL	DIMENSIONS MILLIMETER			DIMENSIONS INCH		
	MIN.	NOM.	MAX.	MIN.	NOM.	MAX.
A	1.40	1.50	1.60	0.055	0.059	0.063
B	0.42	0.49	0.56	0.017	0.019	0.022
B1	0.36	0.42	0.44	0.014	0.016	0.019
C	0.35	0.40	0.43	0.014	0.016	0.017
D	4.39	4.50	4.60	0.173	0.177	0.181
D1	1.40	1.62	1.83	0.055	0.062	0.072
E	2.29	2.44	2.60	0.090	0.098	0.102
E1	1.77	2.03	2.29	0.070	0.074	0.090
e	1.50 BSC			0.059 BSC		
e1	3.00 BSC			0.118 BSC		
H	3.84	4.04	4.25	0.151	0.155	0.167
L	0.74	0.97	1.20	0.029	0.041	0.047

- NOTES :
1. DIMENSIONING & TOLERANCING PER ANSII Y14.5M-1982
  2. CONTROLLING DIMENSION : MILLIMETER CONVERTED INCH ARE NOT NECESSARILY EXACT.
  3. DIMENSION B1, 2 PLACES.

## PCB Mounting Pattern

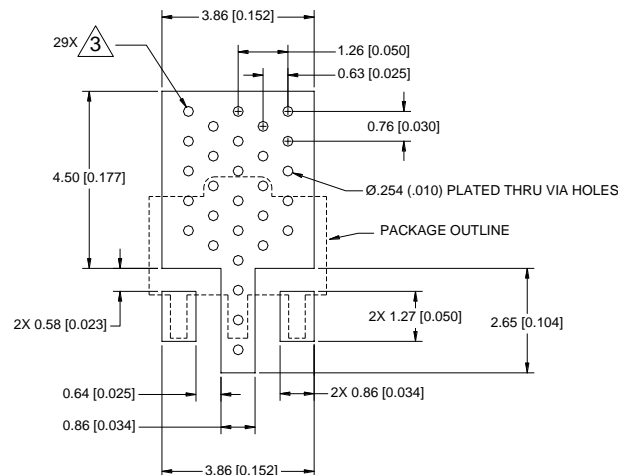

### NOTES:

1. All dimensions are in millimeters[inches]. Angles are in degrees.
2. Use 1 oz. copper minimum for top and bottom layer metal.
3. Via holes are required under the backside paddle of this device for proper RF/DC grounding and thermal dissipation. We recommend a 0.35mm (#80/.0135") diameter bit for drilling via holes and a final plated thru diameter of 0.25mm (0.01").
4. Ensure good package backside paddle solder attach for reliable operation and best electrical performance.
5. Place mounting screws near the part to fasten a backside heat sink.
6. Do not apply solder mask to the back side of the PC board in the heat sink contact region.
7. Ensure that the backside via region makes good physical contact with the heat sink.

**Tape and Reel Information – Carrier and Cover Tape Dimensions**

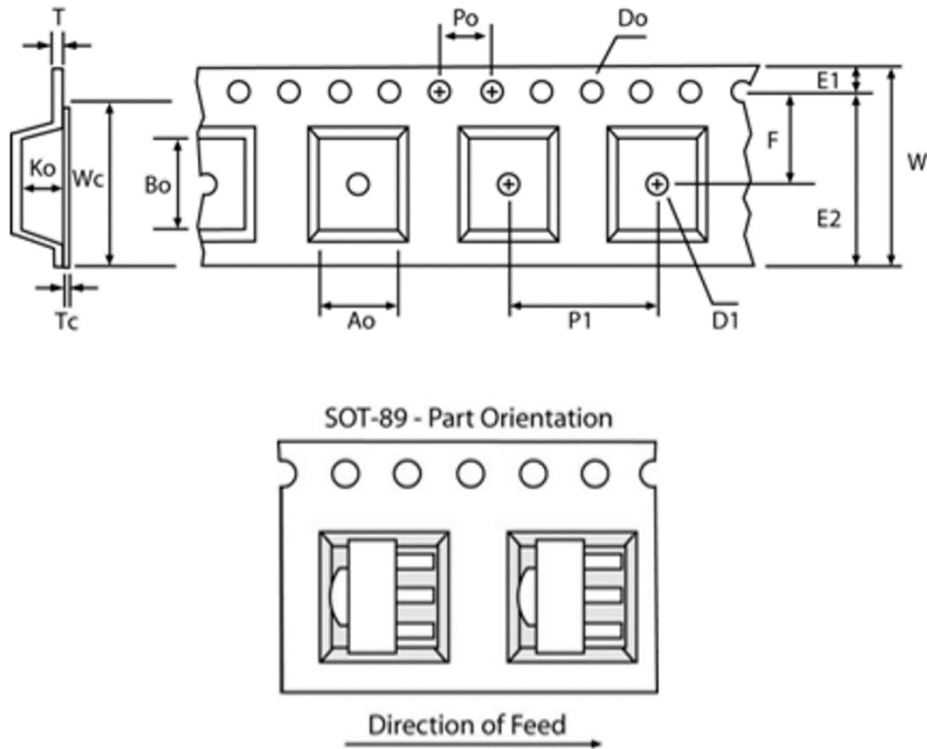

Feature	Measure	Symbol	Size (in)	Size (mm)
Cavity	Length	A0	0.181	4.60
	Width	B0	0.193	4.90
	Depth	K0	0.075	1.90
	Pitch	P1	0.315	8.00
Centerline Distance	Cavity to Perforation - Length Direction	P2	0.079	2.00
	Cavity to Perforation - Width Direction	F	0.217	5.50
Cover Tape	Width	C	0.362	9.20
Carrier Tape	Width	W	0.472	12.0

**Tape and Reel Information – Reel Dimensions**

Standard T/R size = 1,000 pieces on a 7" reel.

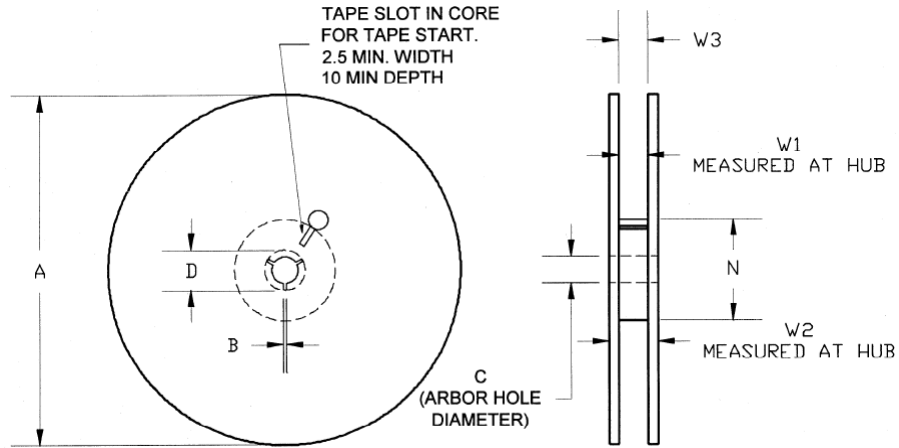

Feature	Measure	Symbol	Size (in)	Size (mm)
Flange	Diameter	A	6.969	170.0
	Thickness	W2	0.717	18.2
	Space Between Flange	W1	0.504	12.8
Hub	Outer Diameter	N	2.283	58.0
	Arbor Hole Diameter	C	0.512	13.0
	Key Slit Width	B	0.079	2.0
	Key Slit Diameter	D	0.787	20.0

**Tape and Reel Information – Tape Length and Label Placement**

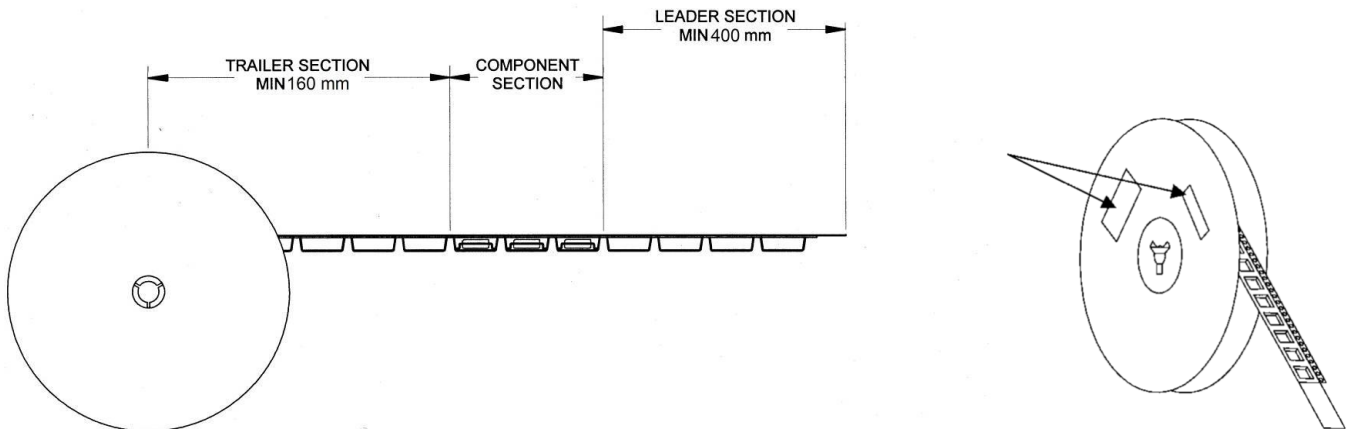

- Notes:
1. Empty part cavities at the trailing and leading ends are sealed with cover tape. See EIA 481-1-A.
  2. Labels are placed on the flange opposite the sprockets in the carrier tape.

## Handling Precautions

Parameter	Rating	Standard
ESD – Human Body Model (HBM)	Class 1A	ESDA / JEDEC JS-001-2012
ESD – Charged Device Model (CDM)	Class C3	JEDEC JESD22-C101F
MSL – Moisture Sensitivity Level	Level 1	IPC/JEDEC J-STD-020



Caution!  
 ESD-Sensitive Device

## Solderability

Compatible with both lead-free (260°C max. reflow temp.) and tin/lead (245°C max. reflow temp.) soldering processes. Solder profiles available upon request.

Contact plating: Matte Tin

## RoHS Compliance

This part is compliant with 2011/65/EU RoHS directive (Restrictions on the Use of Certain Hazardous Substances in Electrical and Electronic Equipment) as amended by Directive 2015/863/EU.

This product also has the following attributes:

- Lead Free
- Halogen Free (Chlorine, Bromine)
- Antimony Free
- TBBP-A (C<sub>15</sub>H<sub>12</sub>Br<sub>4</sub>O<sub>2</sub>) Free
- PFOS Free
- SVHC Free



## Contact Information

For the latest specifications, additional product information, worldwide sales and distribution locations:

**Web:** [www.qorvo.com](http://www.qorvo.com)

**Tel:** 1-844-890-8163

**Email:** [customer.support@qorvo.com](mailto:customer.support@qorvo.com)

For technical questions and application information:

**Email:** [appsupport@qorvo.com](mailto:appsupport@qorvo.com)

## Important Notice

The information contained herein is believed to be reliable; however, Qorvo makes no warranties regarding the information contained herein and assumes no responsibility or liability whatsoever for the use of the information contained herein. All information contained herein is subject to change without notice. Customers should obtain and verify the latest relevant information before placing orders for Qorvo products. The information contained herein or any use of such information does not grant, explicitly or implicitly, to any party any patent rights, licenses, or any other intellectual property rights, whether with regard to such information itself or anything described by such information. **THIS INFORMATION DOES NOT CONSTITUTE A WARRANTY WITH RESPECT TO THE PRODUCTS DESCRIBED HEREIN, AND QORVO HEREBY DISCLAIMS ANY AND ALL WARRANTIES WITH RESPECT TO SUCH PRODUCTS WHETHER EXPRESS OR IMPLIED BY LAW, COURSE OF DEALING, COURSE OF PERFORMANCE, USAGE OF TRADE OR OTHERWISE, INCLUDING THE IMPLIED WARRANTIES OF MERCHANTABILITY AND FITNESS FOR A PARTICULAR PURPOSE.**

Without limiting the generality of the foregoing, Qorvo products are not warranted or authorized for use as critical components in medical, life-saving, or life-sustaining applications, or other applications where a failure would reasonably be expected to cause severe personal injury or death.

Copyright 2018 © Qorvo, Inc. | Qorvo is a registered trademark of Qorvo, Inc.