

Product Overview

The QPG6095 Zigbee/Thread/BLE Smart Home Communications Controller provides a fully integrated solution for ultra-low power wireless communications for Smart Home sentroller devices such as thermostats, motion sensors, smart plugs, key pads and door/window sensors. It is compliant with the IEEE Standard 802.15.4 for Zigbee and Thread, and the Bluetooth Core Specification version 5.0 ³ for Bluetooth Smart, providing robust spread spectrum data communication with a highly secure encrypted and authenticated data flow. For Zigbee communications, antenna diversity offers additional robustness in a crowded wireless 2.4 GHz environment.

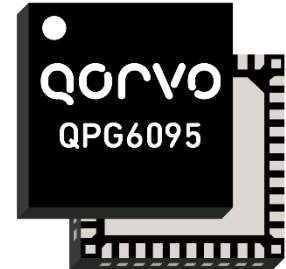

The QPG6095 features a radio transceiver, integrated real-time Medium Access Control and Bluetooth Low Energy (BLE) Controller, integrated Arm® Cortex®-M4 microprocessor, RAM and Flash memory, security engine, event scheduler, and an extensive set of peripherals including analog signal monitors and comparators. The QPG6095 integrated RF baluns and filters reduce the product’s RF design complexity enabling very low cost single layer applications using simple PCB antennas requiring no shielding and a minimum number of external components. The Flash memory allows for software upgrade over the air.

The QPG6095 is capable of running the full stack and applications for Zigbee 3.0, Thread and Bluetooth Smart devices, including the OpenThread open-source implementation of the Thread networking protocols. Integrated multi-stack, multi-protocol support enables stacks to operate concurrently, and on different channels, enabling innovative new applications combining Zigbee, Thread and Bluetooth Smart in one product.

Advanced power management features ensure that power consumption is minimized in active as well as in standby states, enabling maintenance free and very small form factor products. For lower power consumption, the integrated DC/DC Buck converter can be used together with a few external components. Alternatively, the internal regulator can be used instead of the integrated DC/DC converter, to minimize the bill of material.

Chip Overview

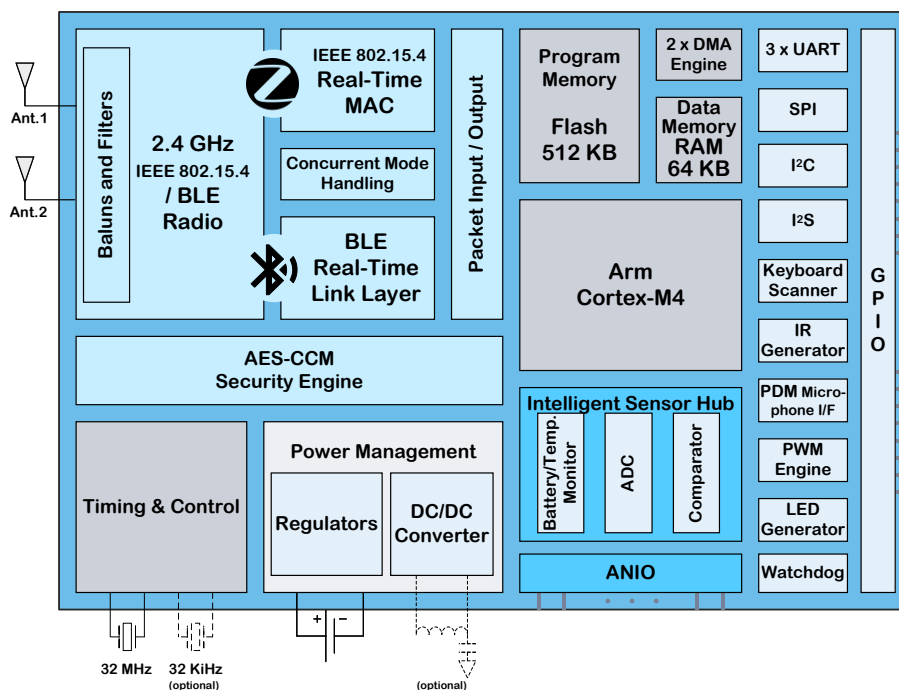

Key Features

- Operates in the worldwide 2.4 GHz ISM-band
- Integrated baluns and RF filters
- Support for external LNA and/or PA
- IEEE 802.15.4 compliant PHY and Real-Time MAC
 - Preamble-based antenna diversity
 - Packet-in-Packet resynchronization
- Bluetooth 5.0 compliant LE Controller ³
 - High Data Rate (2 Mbits/s)
- Concurrent IEEE and BLE communications
- Multi-Protocol / Multi-Channel support, operating in up to 3 PANs on different channels
- Hardware accelerated AES and CCM* encryption with 128, 192 and 256-bit keys
- Arm Cortex-M4 processor with DSP functionality
- 512 Kbyte Flash Program memory; allows OTA software upgrade
- 64 Kbyte Low Leakage Retention RAM
- Full internal IO pull-up / pull-down support during active and standby states
- Fast and low-power analog measurements

Low Cost

The QPG6095 has 2 single-ended RF ports with integrated matching. No expensive shielding, chip antennas or voltage regulators are required to design a high performance Smart Home application. The integrated Arm Cortex-M4 processor and program memory allow for fully integrated, single chip applications. The integrated Real-Time MAC and BLE Link Layer reduce software complexity and improve stability.

Excellent Range and Reliability

The QPG6095 has been optimized for reliable communication in harsh radio environments. The excellent receiver sensitivity and superior receiver signal processing allow extended coverage. Built-in IEEE 802.15.4 antenna diversity with two antennas improves the reliable link budget by 8 dB resulting in approximately 70% more reliable range compared to similar systems with only one antenna. In high density networks the packet-in-packet resynchronization further improves the communication reliability. The QPG6095 provides a flexible interface to an external FEM or PA to boost the output power.

Ultra-Low Power Consumption

The QPG6095's advanced integrated energy management system allows it to operate from a standard lithium coin cell battery, like the CR2032, as well as from intermittent power supplies like photovoltaic (solar), with a minimum of additional components. It includes ultra-low power voltage level detectors and overvoltage protection circuitry, allowing safe operation and graceful shutdown. The battery lifetime monitor tracks the usage of the battery and provides an early exhaustion warning. The intelligent sensor hub allows for quick and low power measurements during standby. The integrated DC/DC Buck converter can be used to further lower the power consumption in active mode, at the cost of two external components.

General Characteristics

Package	QFN40, 6x6 mm
Operating Temperature	-40 to +105 °C (industrial)
Storage Temperature	-50 to +150 °C
Soldering Temperature	260 °C (10 s max)
Compliance	RoHS

Electrical Characteristics

Standby Mode Currents ¹	
Using internal RC oscillator	1 µA
Using 32KHz crystal oscillator (optional)	1.2 µA
Using 32MHz crystal oscillator	760 µA
Operational Currents ¹ (with / without DC/DC Converter)	
Receive IEEE (single antenna)	4 / 6 mA
Receive IEEE (antenna diversity)	5 / 7.5 mA
Receive BLE	8 / 12 mA
Transmit (at 0 dBm)	10 / 15 mA
Transmit (at 10 dBm)	26 / 38 mA
Supply Voltage	1.8 to 3.6 V
Interfaces and Peripherals	
Programmable GPIO lines	up to 30
Analog input lines	up to 6
Keyboard (HW assisted)	max 8 x 8
8-bit PWM with fading support	4 outputs
16-bit PWM engine	6 outputs
UART interfaces	3 (one for debug)
SPI and I ² C Master and Slave peripheral interfaces	
I ² S Master interface for digital audio devices	
PDM Microphone Interface	
High drive sink (for IR)	
10/12-bit ADC to monitor the analog input lines, the power supply level and the temperature	
Low power comparator	
High speed programming interface	
Crystal Frequency	32.000 MHz (±40 ppm)
Optional	32.768 kHz

Radio Characteristics

Radio Regulations compliant	ETSI EN 300 328 FCC CFR-47 Part 15 ARIB STD-T66
Transmit Power	+10 dBm (adjustable down in 1 dB steps)

IEEE 802.15.4 Radio Characteristics

Standards compliant	IEEE 802.15.4-2003 IEEE 802.15.4-2006
Frequency Band	2400 – 2483.5 MHz
Channels	16 (programmable, 5 MHz steps)
Data Rate	250 kbit/s
Receiver Sensitivity ¹	-100 dBm typical
Antenna diversity gain ² (increases the 'effective' receiver sensitivity to -108 dBm)	8 dB

Bluetooth LE Radio Characteristics

Standards compliant	Bluetooth Core Specification version 4.2, Low Energy
Frequency Band	2402 – 2480 MHz
Channels	40 (2 MHz step size)
Data Rate	1 Mbit/s, 2 Mbit/s ³
Receiver Sensitivity ¹	-96 dBm typical

- 1) Typical, at 3.0 V and 25 °C, unless specified otherwise.
- 2) For typical indoor usage in an environment with 50 ns delay spread and 2 MHz signal bandwidth using the Rayleigh fading model: antenna diversity with 2 antennas results in a 8 dB improved link budget at a 1% outage probability compared to no antenna diversity. The 8 dB in link budget translates into 70% more range, if using a two slope range model with the breakpoint at 10 m and $g_1 = 2, g_2 = 3.5$.
- 3) The QPG6095 is certified for BLE 5.0 with support for the 2 Mbit/s data rate; it does not support other optional BLE 5.0 features like the Long Range Coded PHY and Advertising Extensions.

Reference Designs, Tools and SW

Qorvo reference designs, development kits, software libraries and production platforms provide a quick time-to-market solution for sensor and control devices for Smart Home networks and for other IEEE 802.15.4/BLE communication products.

Contact Information

For the latest specifications, additional product information, worldwide sales and distribution locations:

Web: www.qorvo.com

Tel: 1-844-890-8163

Email: lpw.support@qorvo.com

Important Notice

The information contained herein is believed to be reliable; however, Qorvo makes no warranties regarding the information contained herein and assumes no responsibility or liability whatsoever for the use of the information contained herein. All information contained herein is subject to change without notice. Customers should obtain and verify the latest relevant information before placing orders for Qorvo products. The information contained herein or any use of such information does not grant, explicitly or implicitly, to any party any patent rights, licenses, or any other intellectual property rights, whether with regard to such information itself or anything described by such information. **THIS INFORMATION DOES NOT CONSTITUTE A WARRANTY WITH RESPECT TO THE PRODUCTS DESCRIBED HEREIN, AND QORVO HEREBY DISCLAIMS ANY AND ALL WARRANTIES WITH RESPECT TO SUCH PRODUCTS WHETHER EXPRESS OR IMPLIED BY LAW, COURSE OF DEALING, COURSE OF PERFORMANCE, USAGE OF TRADE OR OTHERWISE, INCLUDING THE IMPLIED WARRANTIES OF MERCHANTABILITY AND FITNESS FOR A PARTICULAR PURPOSE.**

Without limiting the generality of the foregoing, Qorvo products are not warranted or authorized for use as critical components in medical, life-saving, or life-sustaining applications, or other applications where a failure would reasonably be expected to cause severe personal injury or death.

Copyright 2017, 2018 © Qorvo, Inc. | Qorvo is a registered trademark of Qorvo, Inc.

Arm and Cortex are registered trademarks of Arm Limited (or its subsidiaries) in the US and/or elsewhere. All other product or service names are the property of their respective owners.